

OPMT Machining Solutions for Ultra-hard Materials Industry

Light 5X 40V

Vertical 5-Axis Laser Machining Center



With the laser into a new dimension of machining cutting edges of precision tools

Traditional processing methods such as grinding and corrosion often lead to the deterioration of the cutting edge quality of the tool, which in turn affects the processing accuracy and efficiency. In contrast, the innovative laser technology stands out with its unique advantages and wide application benefits. By adopting advanced ultra-precision lasers, not only the processing accuracy, processing speed and economic benefits are improved, but also green environmental protection is achieved. Since no consumables are required, the impact on the environment is greatly reduced.

At present, the main cutting tools used in the 3C industry are PCD/PCBN/CVD, which are mainly used for finishing of light, short, and small product shells and internal precision parts, such as mobile phones, tablet computers, electronic watches, etc. Laser technology can well solve the processing problems of traditional processing technology in processing large curvature surfaces and special-shaped contours of PCD/PCBN/CVD tools.



Perfect combination of Efficiency and Precision

Laser finishing of PCD/PCBN/CVD tools with accuracy $\leq 0.003\text{mm}$

Processing tools display

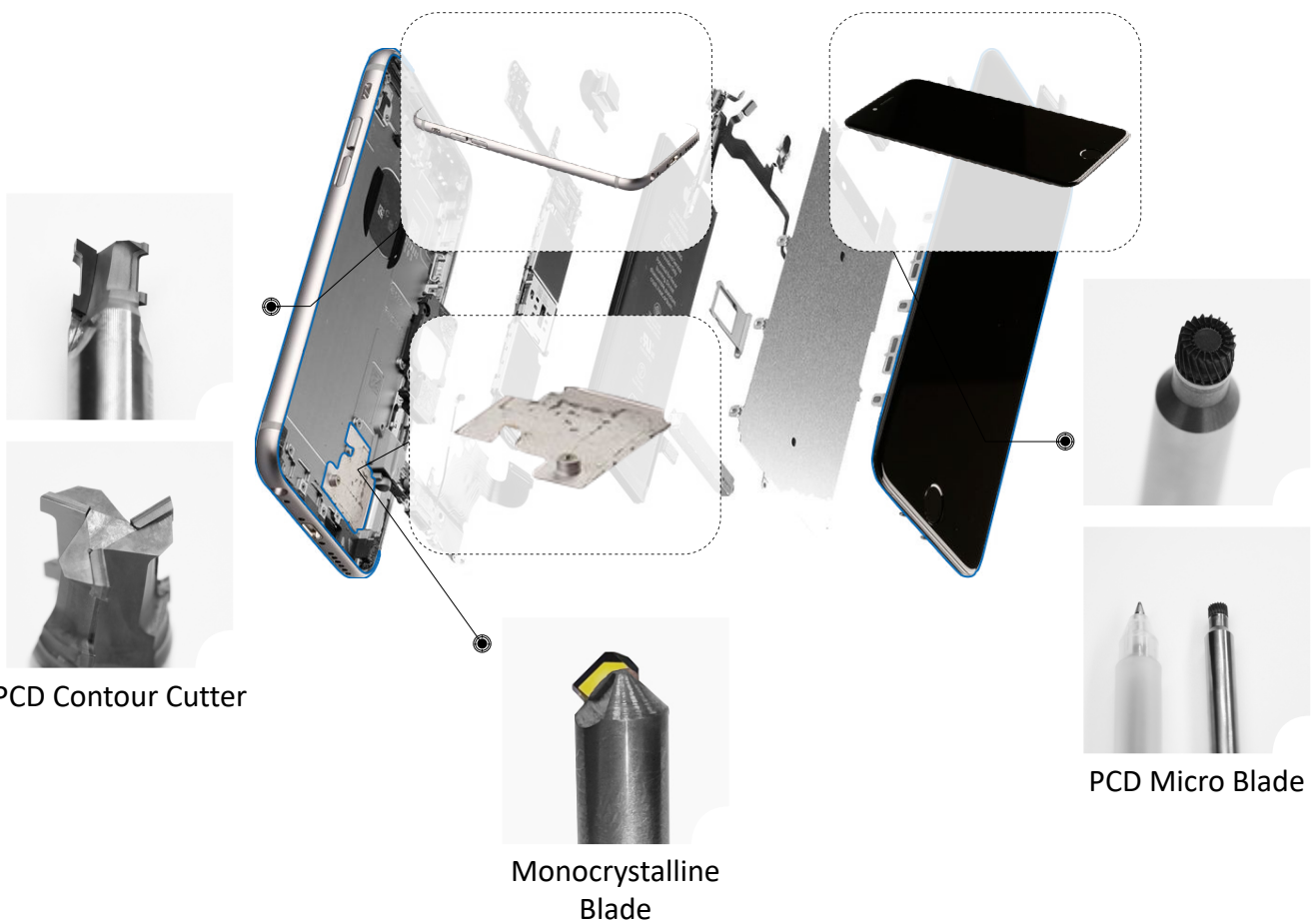

PCD Contour Cutter

Monocrystalline
Blade

PCD Micro Blade

PCD Contour Cutter

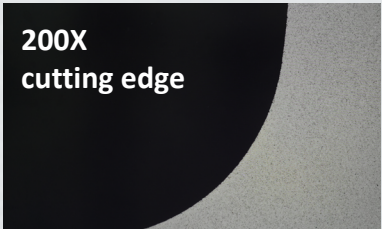
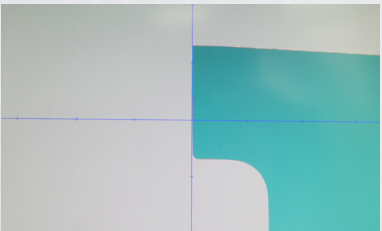
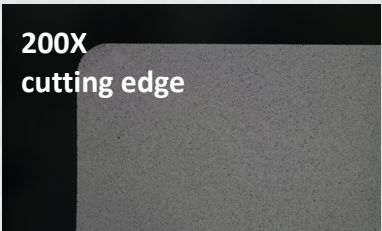

Processing time: 51min37s
Processing accuracy: $\pm 0.005\text{mm}$
Blade width: 0.2mm
Relief angle: 12°
Profile: 0.007mm
Passivation value: 0.00465mm

04

Monocrystalline Blade

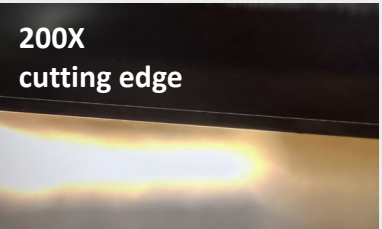
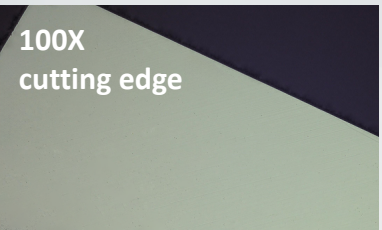

Processing time: 4min26s
Processing accuracy: $\pm 0.008\text{mm}$
Blade width: 0.15mm
Relief angle: 15°
Profile: 0.007mm
Passivation value: 0.00412mm

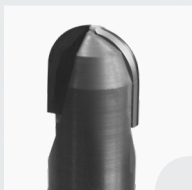



200X Curved cutting edge

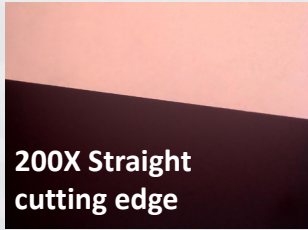

200X Straight cutting edge



100X-Chipping

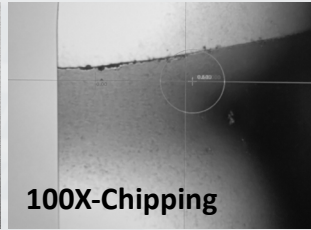

100X-Chipping

Laser process:

- 1-200X curved edge/straight edge without chips
- 2-Processing accuracy in $\leq 0.003\text{mm}$, tolerance stabilized in $\leq 0.001\text{mm}$
- 3-Realizing RTCP 5-axis linkage
- 4-High consistent in lot production
- 5-Ability to process non-conductive materials, such as CVD, MCD

Traditional EDM:

- 1-Chips and cracks may occur at the cutting edge during processing, resulting in increased costs and longer working hours. In severe cases, the blade needs to be replaced;
- 2-When processing large particles or polycrystalline diamond with poor conductivity, wire skipping will occur and machining can not be continued.

- High speed mode 3.0 = 200% faster and 50% lower costs per unit in comparison to the EDM
- Laser finishing of PCD tools with up to 3.0 mm/min
- Flexible machining of PCD, PCBN, CVD
- Individual cutting edge machining -negative chamfers, sharp cutting edge $< 0.001\text{mm}$
- **PERFECT CUTTING EDGES**
Complete machining including relief angle, chip breaker, defined cutting edge chamfering of ultra-hard materials
- High degree of flexibility, quick switching between different processing tasks
- Environmentally friendly, no cutting fluid required, reducing pollution

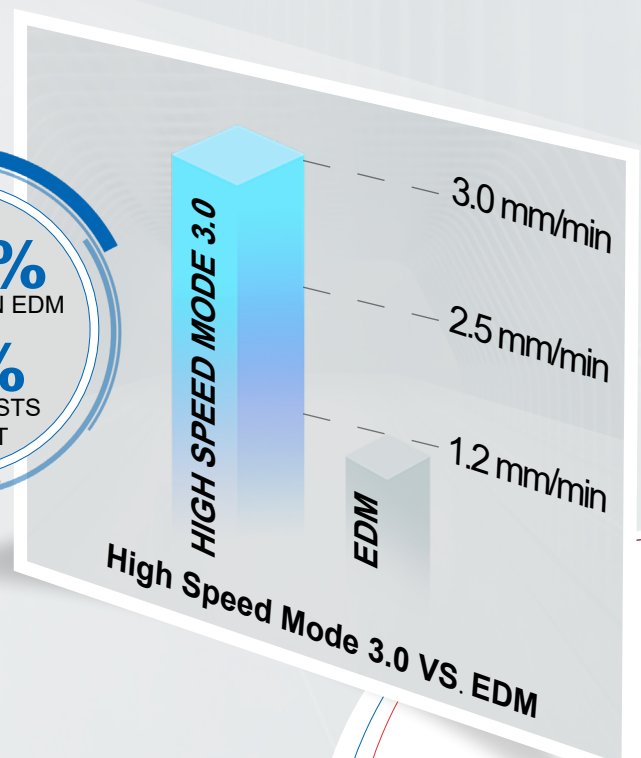
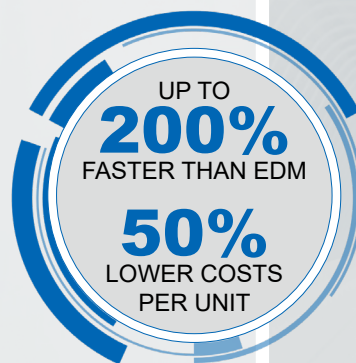

Highly dynamic 5-axis laser precision machine with linear drives

06

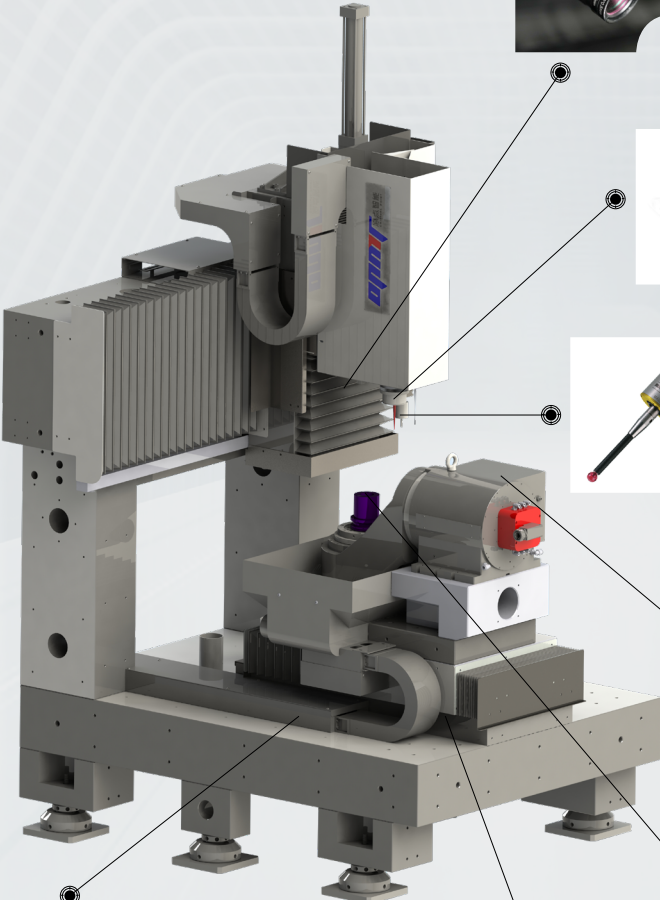

High-magnification CCD camera

- Ultra-precise workpiece visualization
- Real-time spatial positioning for high-accuracy
- Enhanced quality control through high-resolution imaging

Telecentric field lens

State-of-the-art infrared measuring probe

- High-precision workpiece measurement in three dimensions
- Intelligent spatial positioning for optimal processing

B/C-axis Turntable

- Using high-precision torque motors

Clamping interface of workpiece

- HSK-A63 manual clamping interface

Grating scale

- Full closed-loop for fast dynamic response

Long-term stability

- Natural marble base

•The X/Y/Z linear axes utilize linear motors combined with roller guides, offering rapid response times and high precision. The positioning accuracy is $\leq 0.005\text{mm}$ (5 microns).

Technology features for an optimized process and the highest flexibility

Work area

- B-axis swing angle: $\pm 120^\circ$



07

Powerful and user-friendly NUM CNC control system

- Ensures maximum ease of operation and process reliability, combine high-tech performance with genuine customer benefits and ensure application-orientated, simple programming and operation



- The open universal CNC system can meet various machine tool applications such as turning, milling, planing, grinding, laser, water jet, etc.

- The core of the CNC system is NCK, each NUM® system composed of 8 NCKs, each NCK provides up to 32 axes/spindles, and provides up to more than 200 axes/spindles, and is compatible with RTCP.

Undergoes rigorous testing and calibration to maintain high precision and reliability

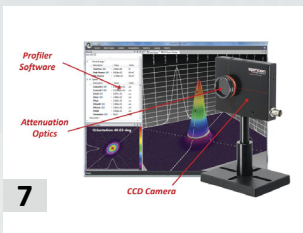
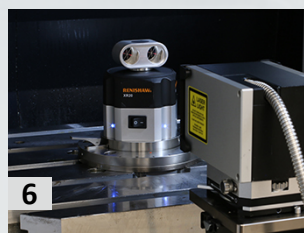
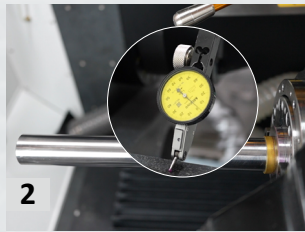

- 1 X/Y/Z-axis parallelism accuracy detection
- 2 B/C-axis parallelism accuracy detection
- 3 Precision line parallelism accuracy detection
- 4 Ballbar
- 5 Alignment laser
- 6 Rotary axis calibrator
- 7 Laser beam profiler
- 8 Laser interferometer

Perfect cutting edges

Complete machining including relief angle, chip breaker, defined cutting edge chamfering of extremely hard materials.



1



2



3

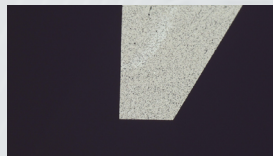

- 1 ZOLLER-Setting for tool presetting
- 2 ZOLLER-Presetting and Measuring Machine
- 3 Laser microscope

10

Overview of the Light 5X 40V

Machine dimensions	Unit	Light 5X 40V
Floor space (L x W x H)	mm	1700 x 1900 x 2600 (incl. 2700 x 1900) accessory
Weight	kg	3500

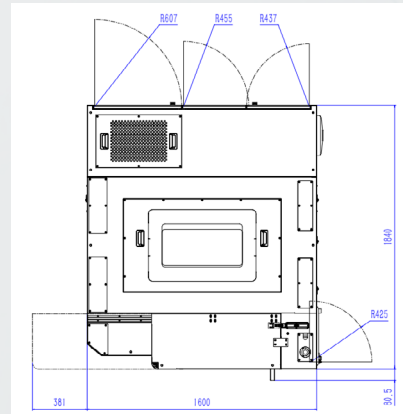
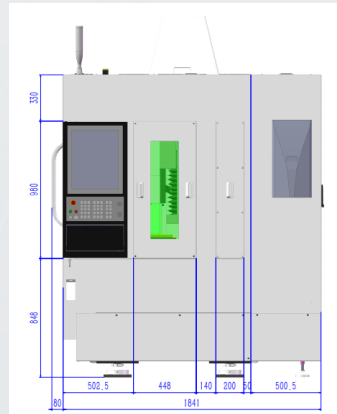
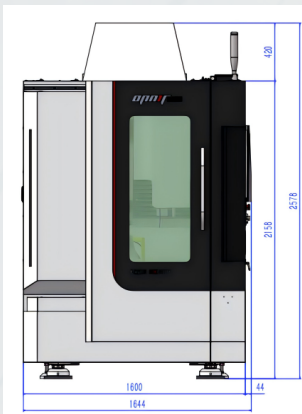

Overview of the Light 5X 40V

- Technical data

Travel	Unit	Light 5X 40V
X-axis (left and right along the sliding plate)	mm	400
Y-axis (forward and backward the workbench)	mm	250
Z-axis (up and down the laser head)	mm	300
Workbench		
Dimensions of the horizontal workbench	mm	500 x 500
Load capacity of the horizontal workbench	kg	100
Dimensions of the C-axis workbench	mm	φ100
B-axis swing angle	°	±120°
B-axis rated/max. speed	rpm	100/150
C-axis rated/max. speed	rpm	200/300
Max. load capacity of the C-axis workbench	kg	10
Feed rate		
Cutting speed	m/min	20
X/Y/Z-axis rapid traverse speed	m/min	30
Accuracy		
X/Y/Z-axis positioning accuracy	mm	0.005
X/Y/Z-axis repeat positioning accuracy	mm	0.003
B/C-axis positioning accuracy	"	10
B/C-axis repeat positioning accuracy	"	5
Laser		
Pulse width	//	ns
Power	W	100
Machining range		
Max. tool diameter	mm	φ100mm(φ200 in special shape)
Max. tool length	mm	200
Max. tool weight	kg	8
Clamping interface of workpiece	HSK-A63 manual clamping interface	
Power		
Power supply voltage	V	AC380V±10%
Electric capacity	KVA	23
Air supply		
Air supply pressure	Mpa	≥0.7MPa
Air supply flow rate	L/min	≥500L/min

Obtained RoHS certification, ISO14001 and ISO45001 management system certification

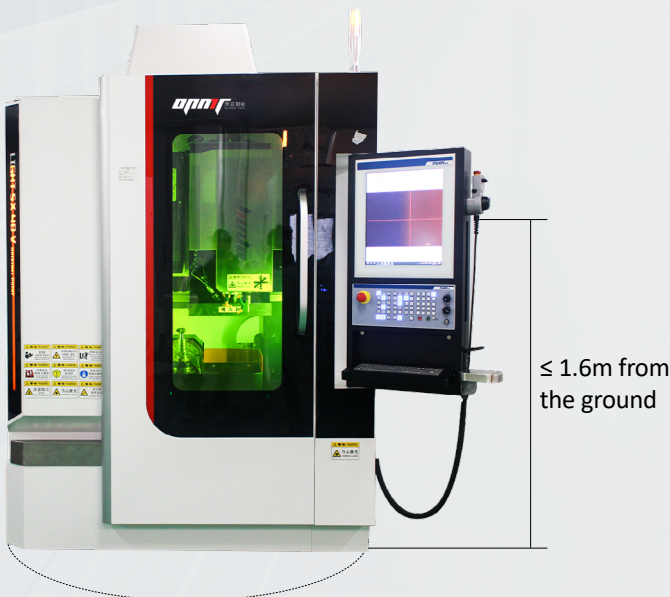

● Dedicated protective glass

The machine operation interface and the protective window are in the same direction which is convenient to operate. The protective window adopts special design to prevent burns from the laser light source and facilitate monitoring of the processing process.

● Laser CNC machine tool safety lock device

Effectively improve the safety of operators and maintenance personnel, reduce the risk of personal injury, and reduce facility maintenance costs.

● Ergonomic structural design

The operator adjustment space is within 1.6m from the ground.

Turnkey provider with impressive technology expertise

Cover 30,000 m², 210 employees, multi-axis CNC laser machine manufacturer, and provide smart factory manufacturing solution



Factory in Foshan, Guangdong, China

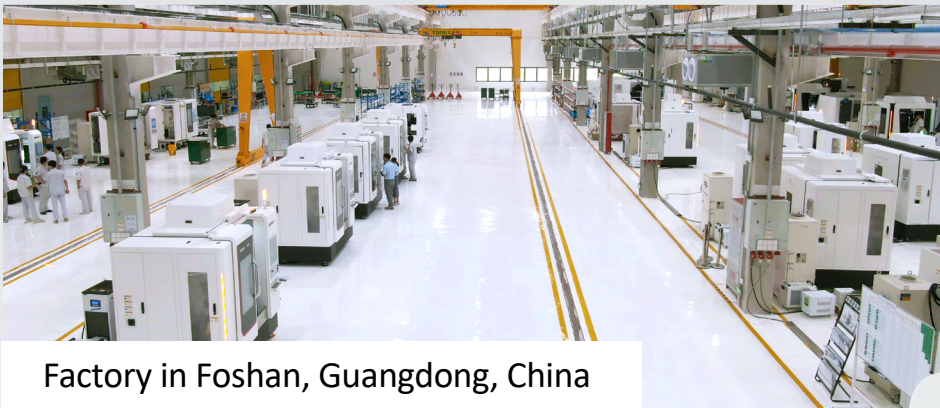

Factory in Foshan, Guangdong, China



R&D Centers & Labs

1,000 sets/year
Full production capacity

300⁺ Patents

302 patents for inventions, utility models, etc.
62 invention patents,
147 utility model patents,
17 exterior design and
9 software

113 R&D Employees

54% total employees
7 PH.Ds
7 Masters,
65 Undergraduates, covering talents in various fields such as Laser application, Mechanics, Electrics and Software

5 R&D Centers & Labs

Provincial Manufacturing Innovation Center,
Engineering Technology Research Center,
Ultrafast Laser Processing Joint Laboratory,
Foshan Postdoctoral Workstation,
Graduate Student Joint Training Demonstration Site

● **EASY MAINTENANCE**

Use high-end international universal accessories

● **FLEXIBLE CUSTOMIZATION**

Customized base on customer needs

● **TRAINING PROGRAM**

Provide operation training



Guangdong Original Point Intelligent Technology Co., Ltd.

To make manufacturing smarter and intelligent manufacturing easier

Adress: No.3 Lizhong Road, Danzao Town, Nanhai District, Foshan, Guangdong, China

September 2024 edition



From origin to infinity